

2

1

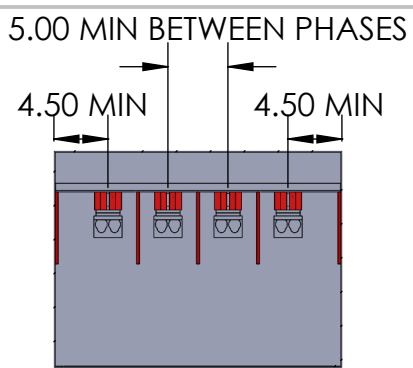
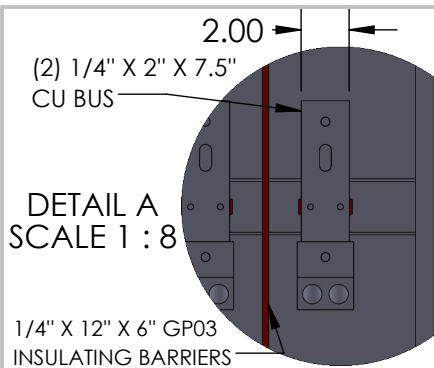

- NOTES:
1. BOX AND COVER CONSTRUCTION - GALV STEEL (12GA)
FINISH: POWDER COAT GRAY ENAMEL
 2. BUS BARS - COPPER 98% CONDUCTIVITY
 3. BOX SHALL HAVE NAMEPLATE WITH MANUFACTURER'S NAME
 4. FRONT COVER SHALL BE SEALABLE WITH (2) HANDLES
 5. LINE SIDE: PROVISION FOR (1) 600 MCM - LUGS NOT INCLUDED
 6. LOAD SIDE : MOUNT UP TO (3) 600 MCM - MECHANICAL LUGS INCLUDED
 7. NEMA 1 CONSTRUCTION: STITCH WELDED ENCLOSURE
 8. "120/208v" BLACK LABEL WITH WHITE LETTERING LOCATION ON INSIDE AND OUTSIDE OF THE ENCLOSURE
 9. FOR 120/208V SERVICE ONLY
FOR 277/480V SERVICE SEE 348210-72-N1 OR 348211-96-N1

B

B

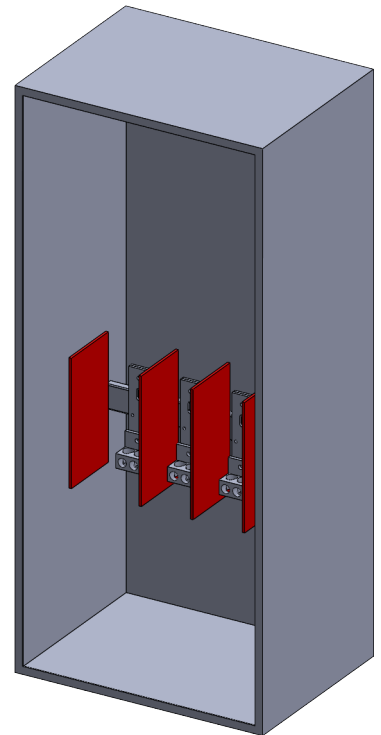
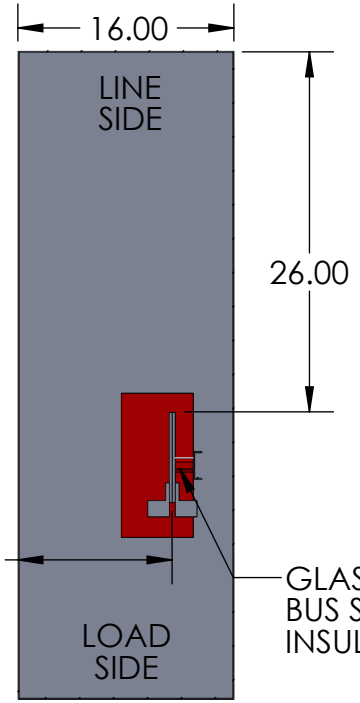
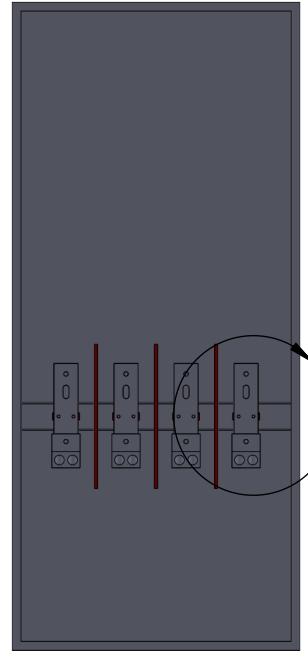
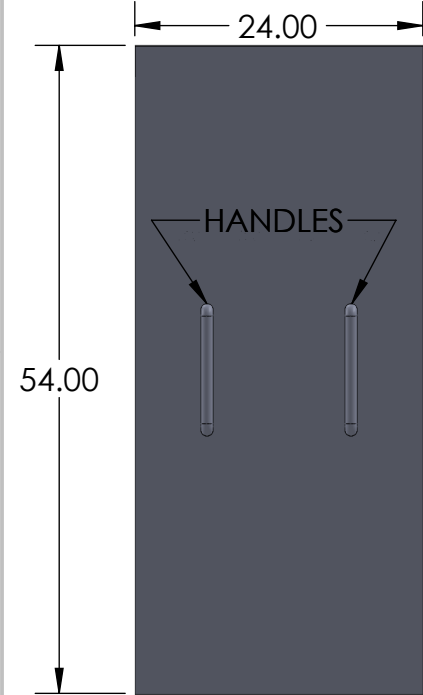

A

A

	NAME	DATE
DRAWN BY	N. BOSETTI	12/30/2025
APPROVED BY		

PROPRIETARY AND CONFIDENTIAL
THE INFORMATION CONTAINED IN THIS DRAWING IS THE SOLE PROPERTY OF Nav-Tech Inc. ANY REPRODUCTION IN PART OR AS A WHOLE WITHOUT THE WRITTEN PERMISSION OF Nav-Tech Inc. IS PROHIBITED.



155 MARCUS BLVD
HAUPPAUGE, NEW YORK 11788
PH: (718) 257-2111 FAX: (718) 257-2626

UNLESS OTHERWISE SPECIFIED:
TOLERANCE:
FRACTIONAL ±1/64 ANGULAR: MACH ± 30°
BEND ± 1°
0.00" = ± 0.01"
0.000" = ± 0.005"
DIMENSIONS IN INCHES [SECONDARY IN MM]

MATL: 12 GA GALV
FINISH: POWDER COAT GRAY
WEIGHT:

UNLESS OTHERWISE SPECIFIED

1. REMOVE ALL BURRS AND BREAK ALL SHARP EDGES .015 X 45° OR .015R
2. DIMENSIONAL LIMITS APPLY AFTER PLATING
3. MACHINED SURFACES EXCEPT AS NOTED

DRAWING TITLE: EO-54-N1 CUT SHEET

PART #: NAV-EO-54-9525B

DESCRIPTION:
NEMA 1 SERVICE BOX
120/208V SERVICE UP TO 1 SET LINE SIDE
SPECIFIED TO CON ED EO-9525-B

DO NOT SCALE DRAWING	SCALE: 1:16	SIZE A	SHEET 1 OF 1	REV. 7
-----------------------------	-------------	--------	--------------	--------

2

1